

Intraground™ N1 Series Nonmetallic Manual Motor Starters

Explosionproof

UNILETS™ for Use with Threaded Metal Conduit.

NEC:

Class I, Division 1 and 2, Groups C, D
NEMA 3, 4X, 7CD ①, 12

Applications

- Listed for use in Class I, Groups C and D, Division 1 and 2 atmospheres, such as:
 - Diethyl ether
 - Methyl ethyl ketone
 - Acetone
 - Toluene
 - No. 3 fuel oil
 - Ammonium hydroxide (20%)
 - Benzene
 - Regular unleaded gas
 - Ethyl acetate
 - Hexane
 - Methanol
- Not suitable for ethylene dichloride and partially halogenated hydrocarbons. Sealing fittings must be field installed adjacent to enclosure on all conduit runs.
- Explosionproof. With sealing fittings installed at each conduit entrance, the N1 Series enclosures withstood a hydrostatic test of four times the maximum internal explosion pressure that could be developed from a gas or vapor explosion.

Features

- Nonmetallic construction with metal imbedded grounding grid. No need to install special wires and parts for grounding. Feed-thru and dead-end styles are grounded through 1/2" or 3/4" threaded conduit openings.
- Special grounding wire furnished with each box provides safe grounding when cover is removed.
- Ideal for use in corrosive environments. Nonmetallic enclosures with corrosion resistant parts coated with epoxy. Teflon® ② or Mylar® ② these motor starters offer unsurpassed resistance to chemicals.
- Unique labyrinth-path construction assures flame-tight joint between body and cover.
- Silicone gasket, specially designed for the labyrinth-path joint, prevents entrance of moisture without interfering with the venting of cooled hazardous gases and vapors.
- Typical mechanical properties of 24,500 psi tensile strength, 3% elongation at break, 33,000 psi flexural strength, and 1,200,000 psi flexural modulus.
- Electrical properties of sample specimens: dielectric strength (in air) of 769 at 1/16".
- High strength thermoplastic polyetherimide, together with thick wall (5/16") and sound structural design (rounded corners) provides superior resistance to impact and crushing.
- Excellent resistance to ultraviolet light and water. After 336 hours of immersion in water at +82 °C (+180 °F) and 720 hours of exposure to ultraviolet radiation, there was no appreciable change in tensile strength.
- Excellent conduit connection strength. UL pull-out and bending resistance tests resulted in no effect on conduit connections.
- Excellent resistance to attack by fungi and mold.
- UL Temperature Index (continuous use temperature): +170 °C (+338 °F) electrical properties, +170 °C (+338 °F) mechanical properties with impact.
- Superior flammability resistance.



Standard Materials

- Body and cover: 30% glass-reinforced thermoplastic polyetherimide
- Handle: Nylon 6/6
- Cover bolts: stainless steel
- Gasket: silicone
- Nameplates: aluminum

Standard Finishes

- Cover bolts: Teflon® ②
- Nameplates: Mylar® ②

NEC Certifications and Compliances

- UL Standards: UL 508, UL 698, UL 1203
- UL Listed: E76550

Product Cross Reference

- For classified-location push button, pilot light and selector switch control stations, see *Controls Section*.
- Sealing fittings not furnished. See *Hazardous Location Fittings Section*.

CONTROLS: NEC/CEC EXPLOSIONPROOF MOTOR STARTERS

Appleton®

① Sealing fittings must be field installed adjacent to enclosure on all conduit runs.

② Teflon and Mylar are registered trademarks of E. I. du Pont de Nemours and Company.

Intraground™ N1 Series Nonmetallic Manual Motor Starters

Explosionproof

Enclosures and Covers Have Neutral Color. Non-Factory Sealed.

NEC:

Class I, Division 1 and 2, Groups C, D
NEMA 3, 4X, 7CD ①, 12

CONTROLS: NEC/CEC EXPLOSIONPROOF MOTOR STARTERS



Dead-End



Feed-Thru

N1 Series Manual Motor Starters — Order Heaters From Following Page ③

Poles	Hub Size (Inches) ②	Starter	Catalog Number	
			Dead-End	Feed-Thru
1	1/2 or 3/4	Allen-Bradley	N1D75-1MSAB	N1DC75-1MSAB
1	1/2 or 3/4	Cutler-Hammer	N1D75-1MSW	N1DC75-1MSW
2	1/2 or 3/4	Allen-Bradley	N1D75-2MSAB	N1DC75-2MSAB
2	1/2 or 3/4	Cutler-Hammer	N1D75-2MSW	N1DC75-2MSW

N1 Series Manual Motor Starters without Overload Protection — No Heater Required

Poles	Hub Size (Inches) ②	Starter Furnished	Catalog Number	
			Dead-End	Feed-Thru
2	1/2 or 3/4	Square D	N1D75-2MS	N1DC75-2MS
3	1/2 or 3/4	Bryant	N1D75-3MS	N1DC75-3MS

N1 Series Manual Motor Starters Horsepower Ratings

Allen-Bradley ◀		Poles	115–230 Vac	32 Vdc	115 Vdc	230 Vdc	Heaters
Catalog Number							
Bulletin 600	1	1 HP	—	—	—	(See Following Page)	
Bulletin 600	2	1 HP	—	3/4 HP	3/4 HP	(See Following Page)	
Cutler-Hammer †		Poles	120–240 Vac	32 Vdc	120 Vdc	240 Vdc	Heaters
Catalog Number							
MST01	1	1 HP	1/4 HP	—	1/4 HP	(See Following Page)	
MST02	2	1 HP	1/4 HP	1 HP	1 HP	(See Following Page)	

N1 Series Manual Motor Starters without Overload Protection Horsepower Ratings

2-Poles		3-Poles	
	Rating		Rating
	30 Amp, 250 Vac/Vdc		30 Amp, 600 Vac
Square D	20 Amp, 600 Vac		3HP 120 Vac
Class 2510	1HP 115 Vac	Bryant	7-1/2HP 240 Vac
Type KO-1	2HP 230 Vac	7810-UD	15HP 480 Vac
	3HP 460-575 Vac		15HP 600 Vac

† Cutler-Hammer is a registered trademark of Eaton Corporation.

◀ Allen-Bradley is a registered trademark of Rockwell Automation.

① Sealing fittings must be field installed adjacent to enclosure on all conduit runs.

② Furnished with 3/4" to 1/2" reducer.

③ Starters are furnished with one interchangeable heater. See following page for Heaters. Select heater number from heater selection table and add appropriate suffix to catalog number. For example, a complete catalog number with Allen-Bradley heater: **N1D75-1MSAB-AB1**.

Intraground™ N1 Series Nonmetallic Manual Motor Starter Heaters

Allen-Bradley ◀ and Cutler-Hammer † heaters and starters are not interchangeable with each other.

NEC:

Class I, Division 1 and 2, Groups C, D
NEMA 3, 4X, 7CD ①, 12

The "Full Load Motor Current" listed in the tables below are ratings which determine the proper heat element that should be used with the EDS Series starters. Refer to motor nameplate for its full load motor current. It is our recommendation that for normal conditions the heater element selected should have a capacity of 20 to 25% greater than the full load current of the motor. This applies to standard +40 °C (+104 °F) temperature rise motors. For +50 °C (+122 °F) rise motors, a heater not greater than 115% full load current should be selected.

However, due to the difference between full load motor currents of various motor manufacturers of the same size motors, the above information is approximate.

If selection of heater element is uncertain as might be in the case of a motor subject to frequent starting and intermittent load, it is advisable to contact the starter manufacturer or his local representative giving full particulars, such as motor horsepower, voltage, phase cycles, name or manufacturer or pertinent data that may aid in the selection of the proper heater element.

Allen-Bradley ◀

Full Load Motor Current (Amp)	Add Suffix N1
0.17	-AB1
0.21	-AB2
0.25	-AB3
0.32	-AB4
0.39	-AB5
0.46	-AB6
0.57	-AB7
0.71	-AB8
0.79	-AB9
0.87	-AB10
0.98	-AB11
1.08	-AB12
1.19	-AB13
1.30	-AB14
1.43	-AB15
1.58	-AB16
1.75	-AB17
1.88	-AB18
2.13	-AB19
2.40	-AB20
2.58	-AB21
2.92	-AB22
3.09	-AB23
3.32	-AB24
3.77	-AB25
4.16	-AB26
4.51	-AB27
4.93	-AB28
5.43	-AB29
6.03	-AB30
6.83	-AB31
7.72	-AB32
8.24	-AB33
8.90	-AB34
9.60	-AB35
10.80	-AB36
12.00	-AB37
13.50	-AB38
15.20	-AB39

Cutler-Hammer †

Full Load Motor Current (Amp)	Heater Rating (Amp)	Add Suffix N1
0.40-0.43	0.50	-WH1
0.44-0.48	0.55	-WH2
0.49-0.53	0.61	-WH3
0.54-0.58	0.67	-WH4
0.59-0.64	0.74	-WH5
0.65-0.71	0.81	-WH6
0.72-0.78	0.89	-WH7
0.79-0.87	0.98	-WH8
0.88-0.95	1.10	-WH9
0.96-1.03	1.20	-WH10
1.04-1.15	1.30	-WH11
1.16-1.27	1.45	-WH12
1.28-1.35	1.60	-WH13
1.36-1.51	1.70	-WH14
1.52-1.67	1.90	-WH15
1.68-1.83	2.10	-WH16
1.84-1.99	2.30	-WH17
2.00-2.23	2.50	-WH18
2.24-2.47	2.80	-WH19
2.48-2.71	3.10	-WH20
2.72-2.95	3.40	-WH21
2.96-3.27	3.70	-WH22
3.28-3.59	4.10	-WH23
3.60-3.99	4.50	-WH24
4.00-4.39	5.00	-WH25
4.40-4.79	5.50	-WH26
4.80-5.26	6.00	-WH27
5.27-5.83	6.60	-WH28
5.84-6.39	7.30	-WH29
6.40-7.03	8.00	-WH30
7.07-7.74	8.80	-WH31
7.75-8.46	9.70	-WH32
8.47-9.35	10.60	-WH33
9.36-10.30	11.70	-WH34
10.31-11.35	12.90	-WH35
11.36-12.47	14.20	-WH36
12.48-13.67	15.60	-WH37
13.68-15.12	17.10	-WH38
15.13-16.00	18.60	-WH39

† Cutler-Hammer is a registered trademark of Eaton Corporation.

◀ Allen-Bradley is a registered trademark of Rockwell Automation.

① Sealing fittings must be field installed adjacent to enclosure on all conduit runs.

CONTROLS: NEC/CEC EXPLOSIONPROOF MOTOR STARTERS



Intraground™ N1 Series Nonmetallic Manual Motor Starter

Explosionproof

UNILETS™ for Use with Threaded Metal Conduit.

NEC:

Class I, Division 1 and 2, Groups C, D
NEMA 3, 4X, 7CD ①, 12

Dimensions in Millimeters (Inches)

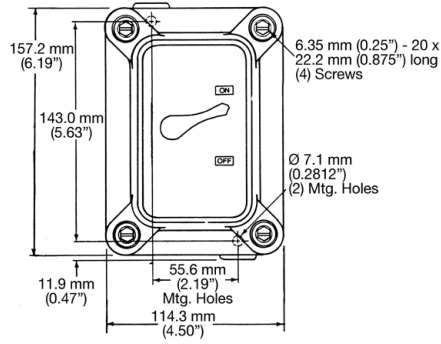

Front

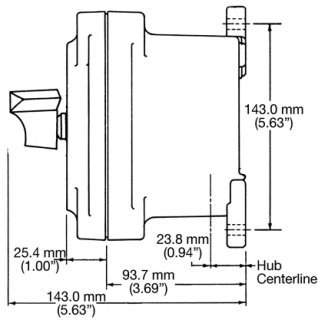

Side

CONTROLS: NEC/CEC EXPLOSIONPROOF MOTOR STARTERS

Appleton®

① Sealing fittings must be field installed adjacent to enclosure on all conduit runs.